

the future of space conditioning

Regula Controls

chilled beams
radiant heating



Regula Controller

Control equipment for waterborne cooling and heating systems.

Use

Regula Mono, Duo and Regula Lon control the cooling and heating of a room in sequence or separately. Regula Secura monitors condensation for safe and optimum operation.

Regula Connect is a connecting card for adaptable connection to façade systems and chilled beams.

Installation

Regula Mono, Duo and Regula Lon can be integrated in an equipment box or directly on the wall. Regula Secura and Regula Connect are either integrated or surface mounted.

Features

User-friendly controller.

Controls heating and cooling in sequence.

Condensation monitor.

Regula controllers

Frenger offers a special range of controllers for waterborne heating and cooling systems. A common feature is that the controllers are all user-friendly with optimum functionality for waterborne heating and cooling systems.

Regula Duo controls heating and cooling in sequence while Regula Mono controls heating or cooling. Regula Mono and Regula Duo operate with the use of an ON/OFF control knob.

Regula Lon is a zone controller with parameter settings in the Lon network. Communication is carried out in accordance with the LonMark Guidelines (Chilled Ceiling Controller 8070) to fully comply with LonMark certification.

Regula Secura is a condensation monitor from Frenger that is compatible with Frenger's waterborne equipment. Regula Secura is mounted on the chilled beam or feed pipe of the equipment box for monitoring of condensation. When detecting condensation, the condensation monitor stops the signal to the actuator, temporarily closing the cooling valve. In the event of a power cut, the valve and actuator remain closed. Regula Secura can be used in combination with Regula Duo, Regula Mono or Regula Lon.

General control functions

The ON/OFF control knob provides a quick and reliable control process with minor temperature fluctuations, $\pm 0.3^\circ\text{C}$. A PI controller is moderately slower with more noticeable temperature fluctuations.

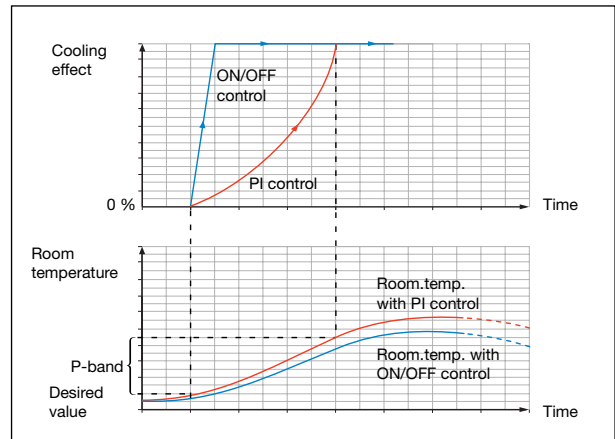

Figure 1. Principle comparison between the function of PI control and ON/OFF control.

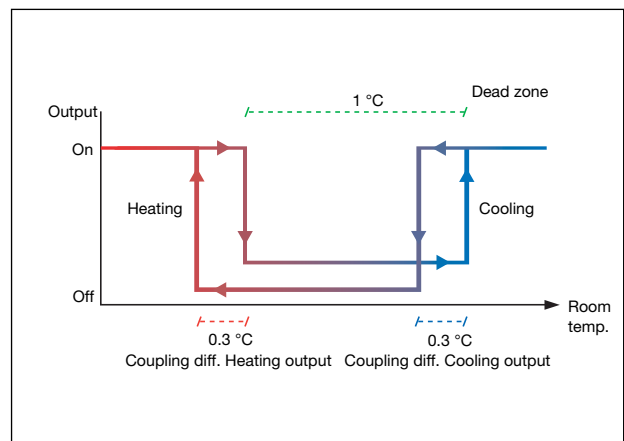

Figure 2. Control process using the ON/OFF control knob.

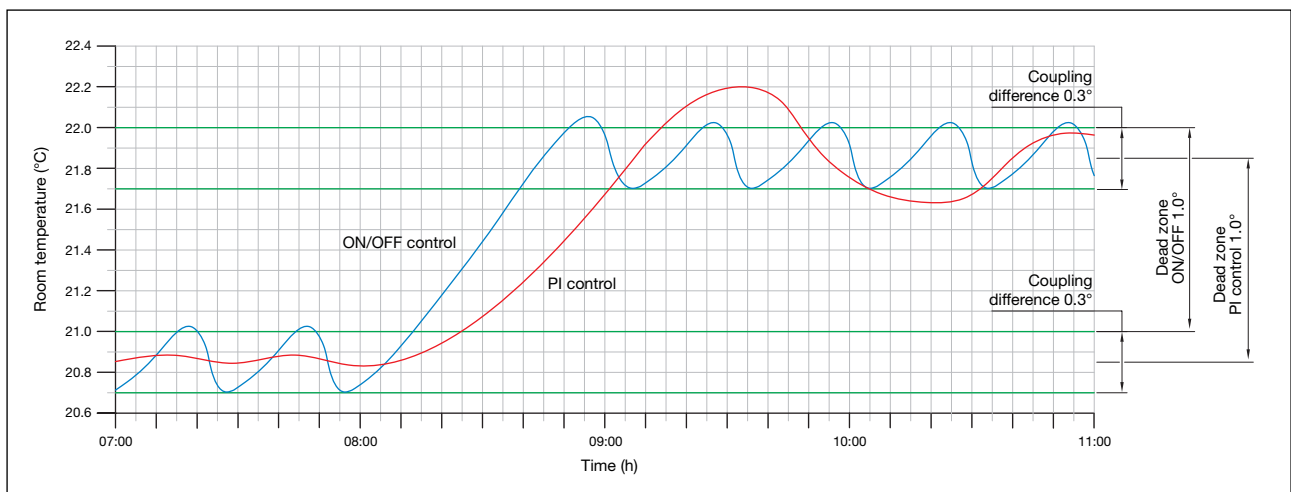

Figure 3. Comparison of ON/OFF and PI control, when alternating between heating and cooling.

Regula Mono/Duo

Function

Regula Mono and Duo are designed for room/individual temperature control where the desired temperature can be adjusted $\pm 4^{\circ}\text{C}$ using the temperature control knob. Regula Mono/Duo can be integrated in an equipment box or directly on the wall.

The controller is available in two models – one for sequence control of heating and cooling (Regula Duo) and one for control of heating or cooling (Regula Mono). Where sequence controlling is used, Regula is connected with electrical cables to a number of actuators – usually one for the cooling circuit and one for the heating circuit. A maximum of 10 actuators per output can be connected. The actuators are in turn mounted on heating and cooling valves that open and close the heating or cooling circuits depending on whether the room needs to be heated or cooled. The control signal governing this process is given from the integrated or external temperature sensor of Regula that compares the desired temperature with the actual temperature. The system continuously attempts to equalize these temperature values as quickly as possible. The control principle engaged for this is called two-step control. There is an integrated coupling difference to prevent the system from being activated too often by temperature fluctuations of less than 0.3°C between the desired and actual temperatures. The power supply required by Regula comes from a 24 V transformer.

Regula Lon

Function

Regula Lon is a zone controller for installation in an equipment box or directly on the wall. Regula Lon is controlled using an integral or external sensor. The ON/OFF control knob controls 2 thermoelectric actuators for heating and cooling in sequence. Each output is controlled by a 24 V triac.

In an analogue setting of PI control, 0...10 V outputs are used to control two thermoelectric 0...10 V actuators for heating and cooling in sequence (direct or reverse effect). The actuators can also be connected using a separate 24 V power supply.

In addition, Regula Lon can be used to control a 3-point motor actuator for either heating or cooling.

The controller is fitted with two inputs for the use of

for example an external room sensor, movement detector, window connector, etc. The desired temperature is set in the Lon network and can be adjusted $\pm 3^{\circ}\text{C}$ using the reference value adjustment knob. The lid has a built-in LED that illuminates in normal mode and flashes in by-pass mode. In addition, the lid has a LED indicating service and communication status.

All parameter settings are carried out in the Lon network. Communication is carried out in accordance with LonMark Guidelines to fully comply with LonMark certification.

Design/Technical data

Design	Regula Mono	Regula Duo	Regula Lon
Supply voltage	24 V AC $\pm 15\%$	24 V AC $\pm 15\%$	24 V AC $\pm 15\%$
Outputs	1 relay	2 relays	2 universal outputs, can be used for: 2 analogue 0...10 V DC, 1 mA or 24 V triac on/off or 1 three-point motor actuator
Inputs	1 temperature sensor	1 temperature sensor	2 universal 1. Room sensor NTC or window connector (non-potential connector) 2. Presence sensor (non-potential connector)
Installation	In equipment boxes or surface mounted.	In equipment boxes or surface mounted.	In equipment boxes or surface mounted.
Output signal	24 V / 2 A on-off. Max. 10 actuators on heating or cooling stages.	24 V / 2 A on-off. Max. 10 actuators on heating or cooling stages.	Outputs, see above.
Service life	>200,000 connections Service life of over ten years.	>200,000 connections Service life of over ten years.	No moving components. Service life of over ten years.
Temperature range	11-29 °C	11-29 °C	Adjustable via the LON network.
Midpoint reference value scale	21 °C (adjustable 15-25 °C)	21 °C (adjustable 15-25 °C)	0-30 °C Adjustable via the LON network.
Dead zone	1 °C	1 °C	Adjustable via the LON network.
Coupling difference	0.3 °C	0.3 °C	Adjustable via the LON network.
Power consumption	1 W	1 W	2 W
Electrical connection	Screw-in plinth	Screw-in plinth or quick connection	Screw-in plinth
Size, controller	85 × 85 × 35 mm	85 × 85 × 35 mm	85 × 85 × 35 mm
Housing	ABS, white	ABS, white	ABS, white
Protection class	IP 20	IP 20	IP 20
Certification	CE	CE	CE
Ambient temperature	0...50 °C	0...50 °C	0...50 °C
Indication, heating	Red signal	Red signal	Temperature via the Lon network
Indication, cooling	Blue signal	Blue signal	Temperature via the Lon network
Reference value adjustment	± 4 °C using reference value adjustment knob	± 4 °C using reference value adjustment knob	± 3 °C using reference value adjustment knob

Electrical wiring diagram

Mono

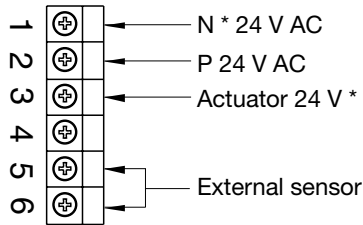

*= to connect the actuator

Duo

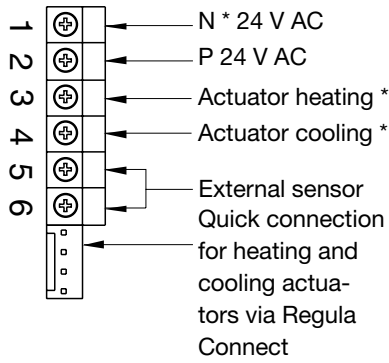

Lon

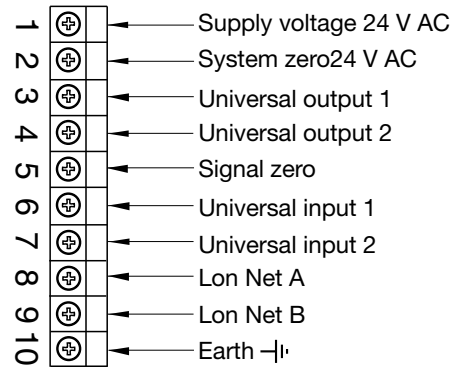

Dimensions, mm

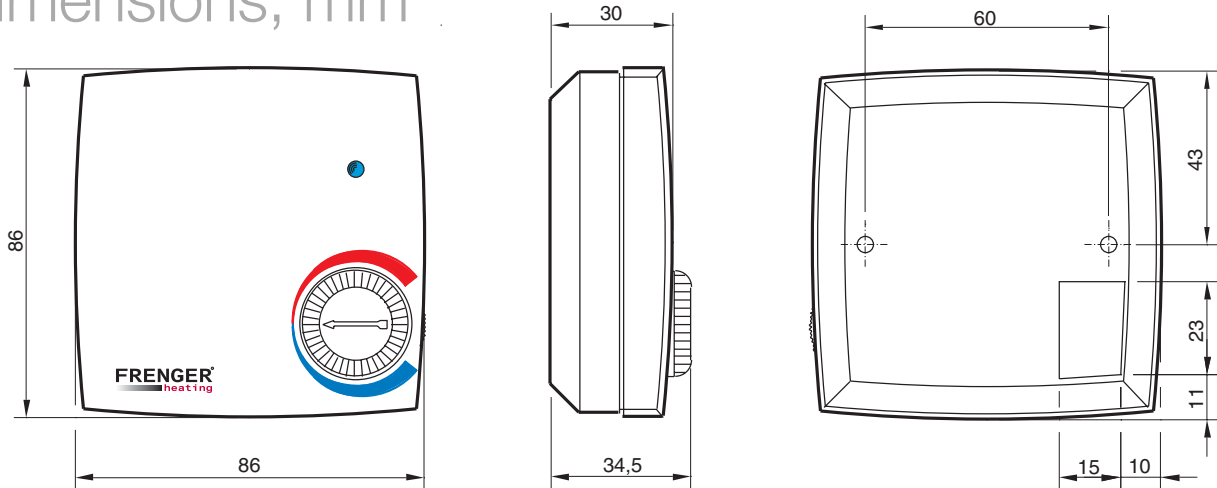

Loops

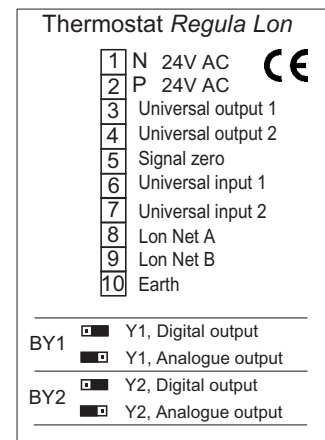
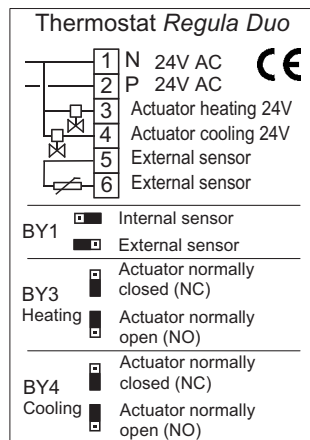
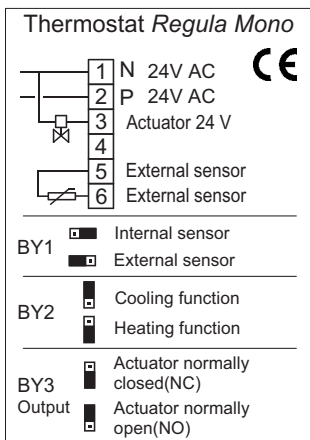

BY 3 and BY 4 are not used in this application. They should always be set to the right.

Regula Secura

Condensation control

Frenger has developed a condensation control for chilled beams and façade systems. The condensation control is called Regula Secura. Since Regula Secura controls actual condensation, a higher efficiency is achieved compared with traditional humidity control. Traditional humidity controls usually measure the average level of humidity with the addition of a water temperature safety margin in order to avoid moisture precipitation. With Regula Secura, safety margins for sensor settings or thermal resistance in pipes are not necessary.

In the event of condensation on the feed pipe, the cooler valve temporarily stops the water flow through the effected equipment. The protection provided by Regula Secura is individual for each chilled beam and façade system, consequently preventing damages due to condensation. Using the ON/OFF function, the condensation control continues to monitor the level of condensation, even below dew point, to allow for an optimal performance by the chilled beam or façade system. The diagram below shows an example of such a control sequence.

Using Regula Secura on all chilled beams and façade systems increases the protection against condensation. Only units with moisture precipitation are shut down until the condensation has desiccated, leaving other units functioning as normal. This is particularly beneficial in room environments with varying temperatures or where there is a risk of outside moisture entering the room through open windows for example.

Function

Regula Secura controls the output signal to the actuator and only operates when there is a signal to the actuator to open the valve. Regula Secura is only activated if the control signal is for cool air. Regula Secura is fitted with a sensor on the feed pipe of the chilled beam or façade system. When the sensor detects condensation on the feed pipe, Regula Secura closes the valve until the condensation has desiccated.

Regula Secura is compatible with electronic controls such as Regula Mono, Regula Duo or any other equipment using thermoelectric actuators. It is important to note that the valve and actuator close in case of a power cut.

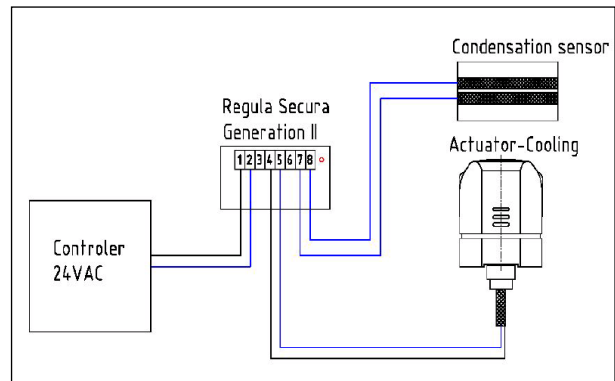

Schematic showing how to connect Regula Secura.

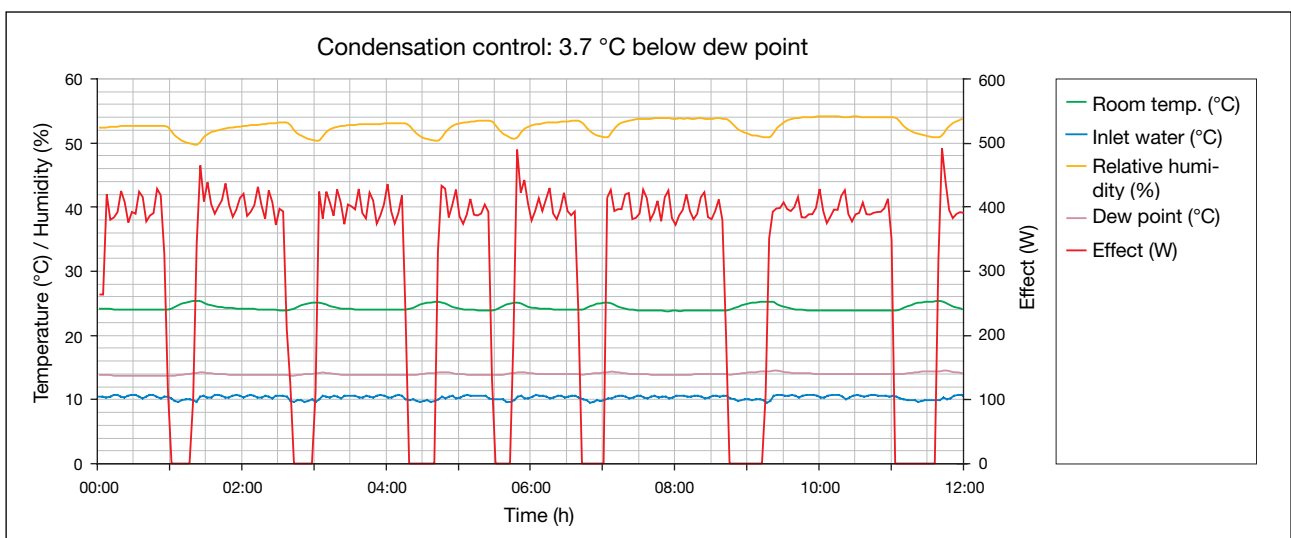

The diagram above shows a control sequence with a water temperature of 3.7 °C below dew point. Throughout the entire control process, the controller asks for cool air, which Regula Secura controls using the ON/OFF function.

Regula Connect

Regula Connect is a connecting card that provides an adaptable connection of chilled beams or façade systems. Regula Connect consists of a connecting card with relay for main cables, thermostat cable and actuator cable plinths. The card has alternative main cable outputs for the control signal to be transmitted to the next chilled beam or façade system in both directions or up to the wall. In addition, a transformer is connected to the unused port.

The system consists of an apparatus cable, connection cable and thermostat cable.

Switching control cables

When moving, erecting new or removing existing partition walls, the control system can be switched over (see picture below) for the control to continue operating the equipment in the room in which it is installed.

The apparatus cable is made up of four parts - two for feed supply and two for control signals to heating and cooling actuators.

The following figures refer to the pictures below.

- 1-2 Connector for connection and relay within the same control zone (feed supply and control signals).
- 3-4 Connector for connection and relay to another control zone (only feed supply).
- 5 Connector for connection of room thermostat (for monitoring of control zone).
- 6 Plinth for connection of actuator. Heating and cooling.

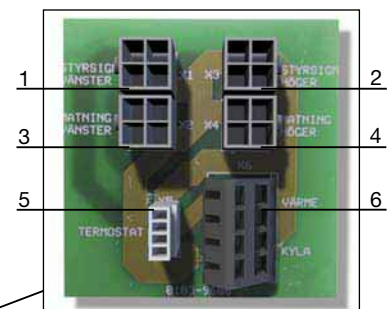
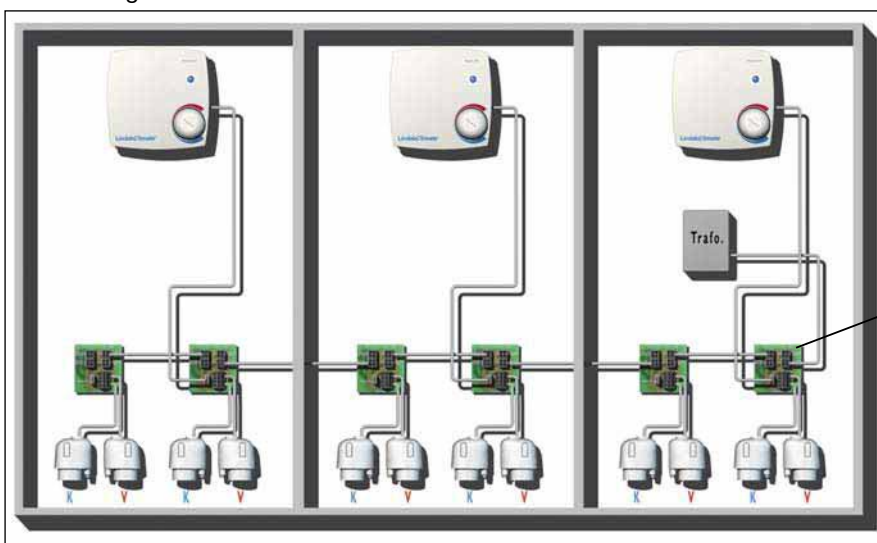

Actuators and valves

The thermoelectric actuator is either fully open or fully closed. The advantages of this are:

1. When the valve is open, full flow always passes through the products, which ensures the stated cooling effect and function. The temperature increase in the room is counteracted quickly, which gives a more comfortable climate. Using fully opened valves you are certain of getting the right cooling effect, despite the dimensioned heating load not prevailing in the building.
2. The risk of blockage due to contaminated pipes is reduced.

Adaption to different valves

The regulating equipment is based on the use of non-pressure valves (heat valves) for regulating both cooling and heating. The actuators match most valves available on the market. Specify in the programme text to which valves the actuator should be matched.

Normally open or closed actuators

Regula can control normally open (NO), or normally closed (NC) actuators. Regula is supplied with settings for an NC type actuator. There is a change-over switch for actuator type NC or NO beneath the removable lid.

Number of actuators per Controller

Up to 10 actuators can be connected per output (cooling or heating) per Controller. When connecting several actuators, a connection box should be used due to space requirements.

Miscellaneous

- There is an indicator on the valve that shows when it is open or closed.
- The actuator is supplied locked with a "first time" function in an open position. When a voltage is fed to the actuator on starting up for the first time (minimum 6 minutes), this function is annulled. The actuator is then ready for use. This can facilitate filling-up and ventilation of the cooling system.
- Actuators are supplied with a 1 m non-halogen cable.



The actuator mounted on the valve. Actuators (NC) and valves with valve function are usually supplied closed in a non-current mode. The pipe fittings shown in the picture can be ordered separately.

Technical data, actuators & valves

Frenger's standard actuators are of the type 24 V NC (normally closed).

Supply voltage:	24 V AC/DC
Power consumption:	80 mA, initially max. 250 mA
Power, operation:	2 W
Opening/Closing time:	Approx. 3 min
Actuating power:	90 N
Cylinder stroke:	Approx. 3 mm
Ambient temperature:	0...50 °C
Protection class:	IP 40

Frenger's standard valves are 2-way FVR valves.

Water temperature:	2...90 °C
Kvs value (fully open valve):	0.01-1.2 (FVR 10,15, 20)
Pressure category:	PN10
Max. differential pressure (across product and valve):	20 kPa
Max. closing pressure:	250 kPa
Cylinder stroke:	1.7 mm
Material:	Brass

Please contact Frenger for information about other types of actuators and valves.

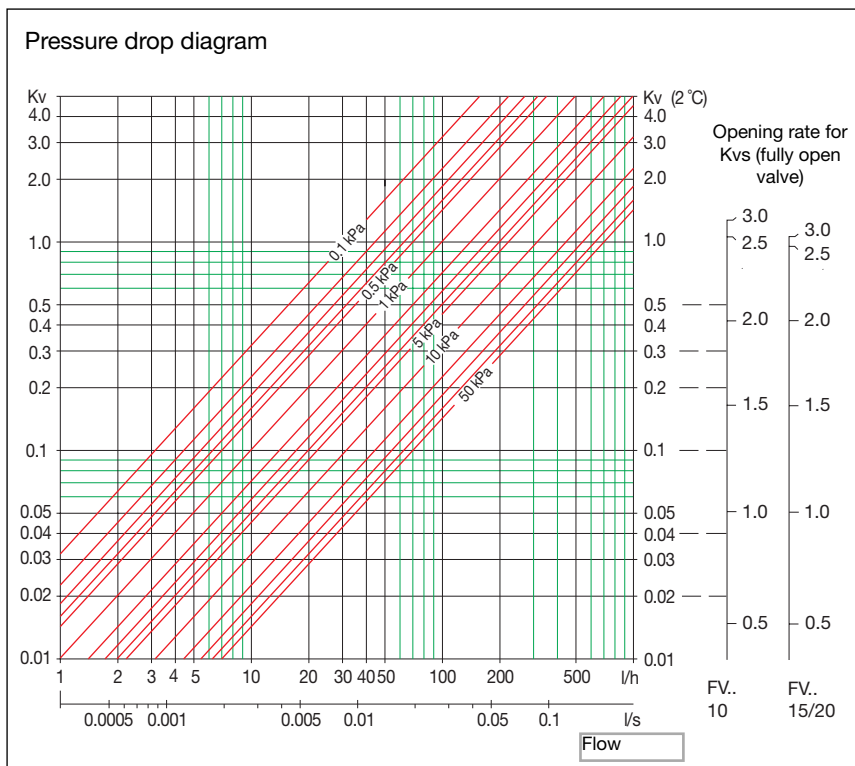

Calculating the transformer size

Conditions

- The transformer size is calculated by taking the most heating or cooling actuators in the building or zone into consideration.
- Consumption when opened is 6 W and in a steady state 2 W. The calculation must take into consideration whether the total power consumption is higher/lower when opening and when at a steady state, respectively. In our example we assumed that 50% of the dimensioned number of actuators open at the same time (depending on the heating load's variation in the building).

Example

15 cooling actuators and 25 heating actuators are installed in the building/zone. Number of heating actuators dimensioned = 25.

Consumption at start is: 6 W x 25 actuators and at a steady state 2 W x 25 actuators.

We calculate the following in accordance with the formula $P = U \times I$:

$$6 \text{ W} / 24 \text{ V} = 0.25 \text{ A per actuator.}$$

$$25 \times 0.25 \text{ A} = 6.25 \text{ A.}$$

Gives a transformer size of $6.25 \text{ A} \times 24 \text{ V} = 150 \text{ VA}$.

Remember to add all actuators if for example NO actuators are used for heating and NC actuators are used for cooling.

Other

Designation

Product designation:
Type:

Regula
Mono, Duo, Lon,
Connect or Secura

Programme text

Controller	Qty
Regula Duo	20
Regula Mono	10
Regula Secura	30
Regula Connect	5
Actuator for cooling 24 V NC	30
Actuator for heating 24 V NC	30
2-way valve FVR-15	60
Transformer 150 VA	1

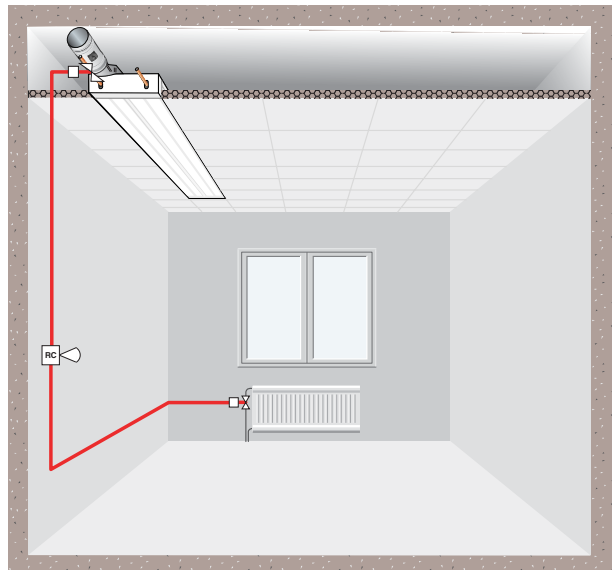

Regula Duo for sequence control of heating and cooling.

